

# Watford & West Herts Scottish Society Summer 2019 Social Dance - 4 July 2019



This Crib by Stuart Kreloff is available at <http://my.strathspey.org/dd/list/21751/>

---

Watford and West Herts Scottish Society Summer Social Dance

Date: Thursday, 4 July 2019 \_ Time: 8.00 pm - 10.30 pm

Venue: All Saints' Church Hall, The Green, Croxley Green WD3 3HJ

Musician: Chris Oxtoby

*\*\* We respectfully request that pre-booking of dances is avoided to assist in the social pleasure for everyone \*\**

Website: <http://www.WatfordScottish.org.uk>

Facebook: <https://www.facebook.com/WatfordScottish>

Revised: 20190401v2

Green = 'Easy' / Amber = 'Worth a Try' / Red = 'Get Help from Friends!'

## 1 PROGRAMME

- 1 Good Hearted Glasgow J32 Knapman: Collins SCD green
- 2 MacDonald of Keppoch M128 Ronald: RSCDS XLIX amber
- 3 The Glens of Angus R32 Henderson: RSCDS XXIII red
- 4 Auchinellan Jig J32 McLean: Auchinellan green
- 5 The Silver Tassie S32 Drewry: RSCDS Leaflets green
- 6 The Queen's View R32 Forbes: Three Hands Across amber
- Interval
- 7 A 100 years behind us! M32 Hartley amber
- 8 The Weathercock J32 Hughes: RSCDS Graded 2 amber
- 9 The Fireworks Reel R32 Lingnau: RSCDS XLVIII amber
- 10 Saint Columba's Strathspey S32 Sproule&Gillan: Leaflet green
- 11 The First Rain of Spring J32 Joubert: RSCDS XLIX red
- 12 The Montgomeries' Rant R32 Castle Menzies (18C): RSCDS X amber

## 2 GOOD HEARTED GLASGOW J32 · 3/4L

Peter Knapman: Collins Pocket Reference: Scottish Country Dancing · Crib: E-cribs · Diagram: Keith Rose's Diagrams

- 1- 1c turn RH | cast off (2c up) ; turn LH 1¼
- 9- Teapots R ; and L (2c+1W & 1M+3c RHA ; 2c+1M & 1W+3c LHA)
- 17- 1c lead down the middle and up into 2pl
- 25- All circle6 and back

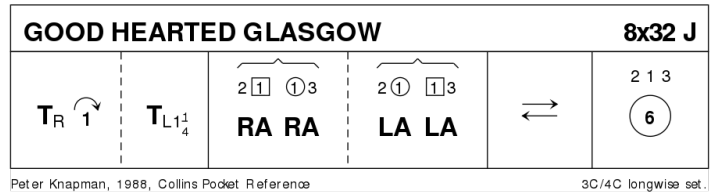

green

## 3 MACDONALD OF KEPPOCH M128 · 4S

Chris Ronald: RSCDS XLIX 11 · Crib: E-cribs · Diagram: Keith Rose's Diagrams

- 1-- 1c+3c 6 bars of R&L to BtoB facing sides | all set
- 9-- Parallel Reels4 across, 1c+3c finish half way the last left pass, in a line up and down the set
- 17-- 1c+3c Lsh Reel4, 1W+3W pass Rsh in middle to start, to finish in original places
- 25-- All set to P | all turn P RH 1¼ | all in promhold chase cclw ¼ cclw (2,3,4,1)

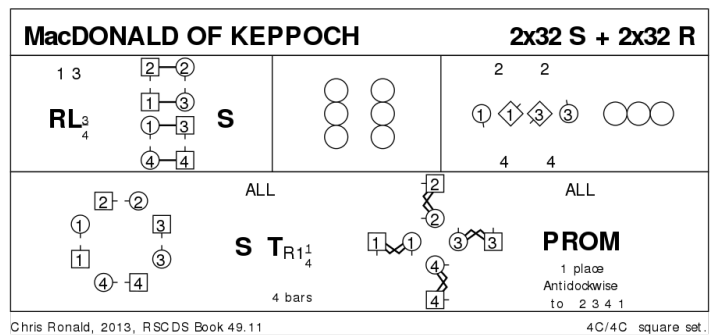

The first two turns are in Strathspey time, the second two are in Reel time.

amber

## 4 THE GLENS OF ANGUS R32 · 4/4L

Douglas Henderson: RSCDS XXIII 3 · Crib: E-cribs · Diagram: Keith Rose's Diagrams

- 1- 1c (passing inside)+2c & 3c(passing inside)+4c change places EH on the side | BiL on sidelines ; change places back same hand | BiL again (1,2,3,4)
- 9- Mirror Reels4 on the sides, the M Rsh, W Lsh, on [11-12] 1c cross down into opposite reel. At end 1c dances through 1plx to finish between 2c in 2pl facing opposite side (for the last pass in middle Rsh is allowed), 3c & 4c finish in places
- 17-32 The Spurtle (½Reel4 across, 2c to 1plx, and 1c makes fast RH turn to between 3c ; repeat with 3c ;; repeat with 4c ; All set and cross RH) (2,3,4,1)

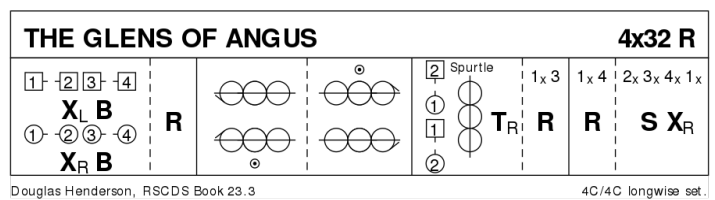

red

## 5 AUCHINELLAN JIG J32 · 3/4L

Alice McLean: *The Auchinellan Collection* · Crib: *E-cribs* · Diagram: *Keith Rose's Diagrams*

- 1- 1c+2c set | RHA | 1c cast as 2c dance up (2,1,3)
- 9- Mirror Reels3 on own side, 1c start in and down
- 17- 1c ½Fig8 Left (M up, W dn) ; all chase clw ½ round (3x,1,2x)
- 25- Diagonal R&L

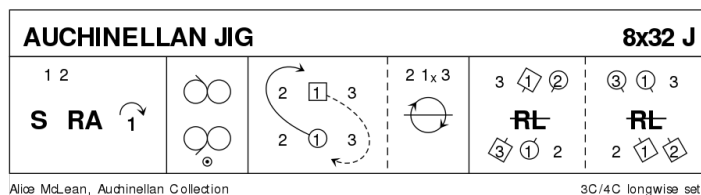

green

## 6 THE SILVER TASSIE S32 · 3/4L

John Drewry: *The Leaflet Dances with Music* · Crib: *E-cribs* · Diagram: *Keith Rose's Diagrams*

- 1- 1c+2c+3c cross RH | set ; repeat
- 9- 1c+3c DbIFig8 round 2c (1c cross down, 3c cast up)
- 17- 1c followed by 2c+3c dance down the middle (2c & 3c divide) ; 1c (leading) +2c+3c dance up
- 25- 1c+2c Rondel (2,1,3).

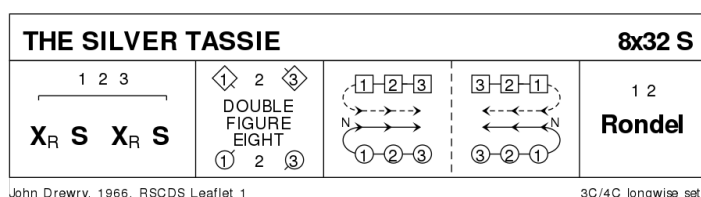

green

## 7 THE QUEEN'S VIEW R32 · 3/4L

Bill Forbes: *Three Hands Across* · Crib: *MiniCribs* · Diagram: *Keith Rose's Diagrams*

- 1-8 1s+2s dance 1/2 double Fig of 8 (1s crossing down to start), 1s dancing between 2s give nearer hand to 2s & turn once round
- 9-16 1s dance Inveran reels with 2s+3s (1s cross to own sides to start)
- 17-24 1s+2s dance 1/2 double Fig of 8 (1s crossing down to start), 1s dancing between 2s give nearer hand to 2s & turn 1.1/2 times to end in centre BtoB for Double Triangles
- 25-32 1s dance Double Triangles ending in 2nd place own sides

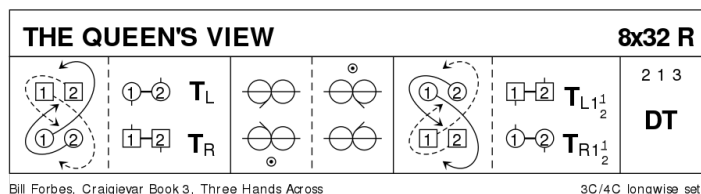

amber

## 8 INTERVAL

## 9 A 100 YEARS BEHIND US! M32 · 3/3L

Jennie Hartley · Crib: E-cribs · Diagram: Keith Rose's Diagrams

- 1-- 1c long cast to 2pl (2c up), dance between 3c and cast up to face 1cnr  
 9-- 1c+1cnrs: centres set to cnr | centres cast away to cnr behind as cnrs dance in and face back ; repeat and 1c turn R about to face 2cnr  
 17-- 1c+2cnrs repeat (3x,1x,2x)  
 25-- 3W with 1W+2W following cast down **while{4}** 2M with 1M+3M following cast up (2x,1x,3x) ; 2c cross RH as 1c+3c ½RHA | All set (2,3,1)

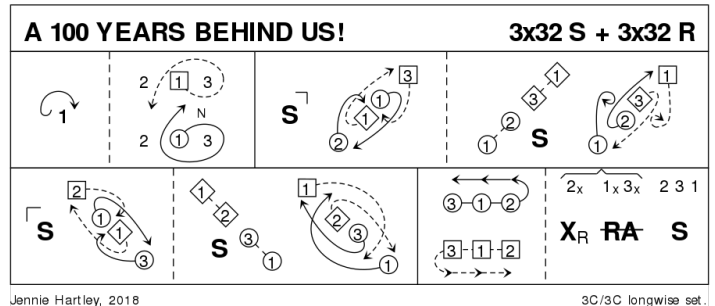

repeat 2 times more in Strathspey time, 3 times in Reel time.

amber

## 10 THE WEATHERCOCK J32 · 4/4L

Veronica Hughes: A Second Book of Graded Scottish Country Dances · Crib: E-cribs · Diagram: Keith Rose's Diagrams

- 1- Parallel Reels 4 on the sides  
 9- 1c+3c set advancing to midline and join RH with P, LH in middle | BiL (2c+4c up) ; 1c+2c & 3c+4c RHA  
 17- 1W+3M turn LH ¾ **while{}** 1M+3W dance round clw ¼ to meet P in line across | BiL ; repeat  
 25- 3c+2c & 1c+4c RHA ; 1c+3c turn person ahead («corner») RH to finish (2,3,4,1) (M turn once and a bit, W turn 1½ and a bit)

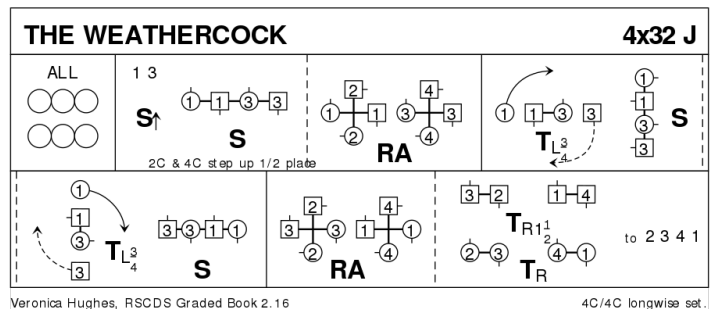

note: the set tends to move upwards; ease down gently in the turns to end in the right positions

amber

## 11 THE FIREWORKS REEL R32 · 3/4L

Anselm Lingnau: RSCDS XLVIII 11 · Crib: MiniCribbs · Diagram: Keith Rose's Diagrams

- 1-8** 1s cross RH & cast 1 place, 1s dance 1/2 figures of 8 (1L round 2s, 1M round 3s) & end facing 1st corners
- 9-12** 1s set moving out between corners (as in Hello-Goodbye setting) & 1s turn LH to face 1st corners
- 13-16** 1s dance 1/2 diagonal reel of 4 with 1st corners & end facing 2nd corners
- 17-24** 1s repeat bars 9-16 with 2nd corners & end 2nd place opposite sides (3)(1)(2)
- 25-32** 1s dance 1/2 reel of 3 on opposite sides (1M in & down, 1L in & up), 1s dance 1/2 reel of 3 across (1M with 2s & 1L with 3s)

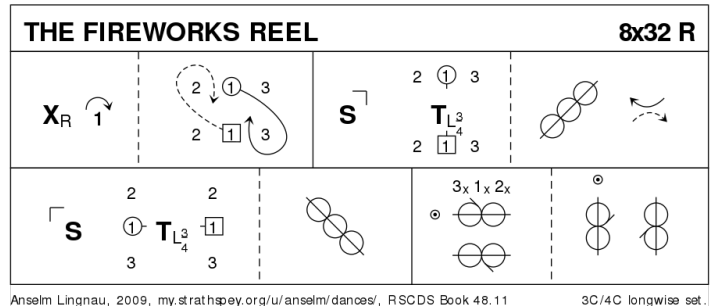

amber

## 12 SAINT COLUMBA'S STRATHSPEY S32 · 5/5L

Vicky Sproule & Sadie L. Gillan: Saint Columba's Strathspey (Leaflet) · Crib: E-cribs · Diagram: Keith Rose's Diagrams

- 1-** 2c+4c RHA ; lead out between end couples and cast back to face 1cnrs
- 9-** 2c+4c cnrs pass and turn (change places Rsh with 1cnrs, who turn RH, change back, pass P Lsh and repeat with 2cnrs), finish with wide curve to midline facing P with M below W
- 17-** Reel4 on the centre line, to own places
- 25-** 2c+3c+4c+5c set | 2c+4c cast off one **while{2}** 3c+5c dance up one (touch NH) ; 1c+2c turn RH and cast off one (3c+5c up). (to 3,1,5,2,4)

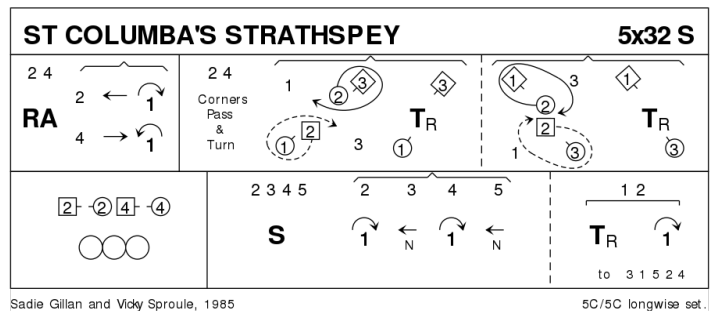

Note: In »corners pass and turn«, 1c normally pass Rsh on [4]; for this dance the instructions explicitly specify Lsh

green

### 13 THE FIRST RAIN OF SPRING

J32 · 3/3L

Wouter Joubert: RSCDS XLIX 4 · Crib: E-cribs · Diagram: Keith Rose's Diagrams

- 1-- 1c dance down below 3c | cast up 1 place ; dance up to 1pl facing out | 1c+2c ½ turn EH, 2c face out
- 9-- 2c+1c DblFig8, 1c crossing up
- 17-20 1c+3c turn P RH ¾ and face P up/dn | set ;
- 21-28 (½ Celtic Reel) 1c+3c pass Rsh | "outers" chase ¼ way clw **while{2}** "inners" turn (no hands) ¾ Lsh to face same person ; repeat
- 29-32 1c+3c Turn P RH ¾ | all set

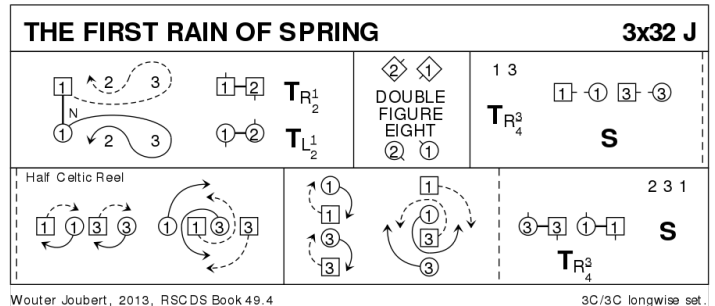

red

### 14 THE MONTGOMERIES' RANT

R32 · 3/4L

Castle Menzies (18C): RSCDS X 1 · Crib: E-cribs · Diagram: Keith Rose's Diagrams

- 1-- 1c cross RH | cast off (2c up) ; cross LH | cast L (W up, M down)
- 9-- 2c+1W & 1M+3c Rsh Reels3 across
- 17-- 1c NHJ set to 2W (swivel ½ inwards), set to 3M (veer L together), set to 3W (swivel ½ inwards), set to 2M (and face own 2cnc)
- 25-- Reels3{6} on the sides, Rsh to 2cnc | 1c cross RH to 2pl

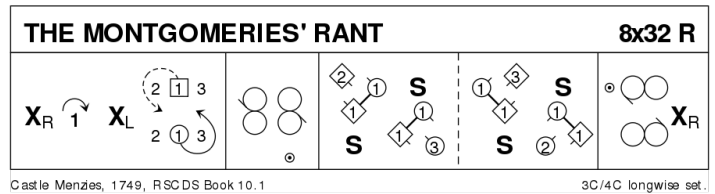

amber