

Watford & West Herts Centenary Caledonian Ball 2019 - 16 March 2019



This Crib by Stuart Kreloff is available at <http://my.strathspey.org/dd/list/17820/>

Watford and West Herts Scottish Society Centenary Caledonian Ball

Date: Saturday, 16 March 2019 _ Time: 7.00 for 7.30 pm - 11.30 pm

Venue: Allum Hall, Allum Lane, Elstree, WD6 3PJ

Band: Ian Robertson and Muriel Johnstone +++

** We respectfully request that pre-booking of dances is avoided to assist in the social pleasure for everyone **

Website: <http://www.WatfordScottish.org.uk>

Facebook: <https://www.facebook.com/WatfordScottish>

Ball practice Sunday 10 March 2019, 2-5 pm, Recital Hall Nascot Wood Junior School,
Nascot Wood Road Watford WD17 4YS - Please contact us if you wish to attend

Revised: 20190113v7

Green = 'Easy' / Amber = 'Worth a Try' / Red = 'Arise and Get Help from Friends!'

PROGRAMME ITEM – # Name Type Source Comment

- 1 EH3 7AF J32 Goldring: RSCDS XL uaine / green
 - 2 H.I.S.C.D. R32 L&D Henderson: SDA òmarach / amber
 - 3 12 Coates Crescent S32 RSCDS XL uaine / green
 - 4 Best Set in the Hall J32 Greenwood: RSCDS XLVI òmarach / amber
 - 5 Anniversary Reel R32 Muir: RSCDS XXXVI òmarach / amber
 - 6 "Deer" Friends S32 Anderson: Saint Martin vol 1 òmarach / amber
 - 7 St Andrew's Fair J32 Goldring: RSCDS 5/1982 uaine / green
 - 8 Jean Martin of Aberdeen S32 Johnstone: Magazine òmarach / amber
 - 9 Father Connelly's Jig J64 Drewry: Donside dearg / red
 - 10 John of Bon Accord R32 Goldring: RSCDS XXXIII òmarach / amber
- Interval
- 11 Pelorus Jack J32 Skelton: RSCDS XLI òmarach / amber
 - 12 Lady Sophia Lindsay R32 Attwood: Alexander Lflts òmarach / amber
 - 13 A 100 Years Behind Us - M 6x32 - Jennifer Hartley red
 - 14 Flora's Fancy J32 Members of Tucson Branch and Seven Pipers Scottish Society country dance class: RSCDS XLIX uaine / green
 - 15 Miss Johnstone of Ardrossan R32 Goldring 2000 òmarach / amber
 - 16 Salute to Ian Robertson S32 Rose òmarach / amber
 - 17 The Australian Ladies R32 Campbell: Glasgow Ass. òmarach / amber
 - 18 The Robertson Rant S80 Winchester: RSCDS XXXIX òmarach / amber
 - 19 The Findlays' Jig J32 Goldring 2000 uaine / green
 - 20 Mairi's Wedding R40 Cosh: 22 SCD òmarach / amber

1 EH3 7AF J32 · 3/4L

Roy Goldring: RSCDS XL 6 · Crib: E-cribs · Diagram: Keith Rose's Diagrams

- 1– 1c lead down the middle and up, on [8]
2c+3c step in for
- 9– 1c+2c+3c Promenade, at end 1c cast
off (to 2,1,3)
- 17– 1c cross Rsh | turn 1c_{nr} RH ; cross
up/dn Rsh | turn 2c_{nr} RH (2,1x,3) |
- 25– 2c+1M & 1W+3c RHA ; 1c ½Fig 8 Rsh round 4c_{nr} (2,1,3)

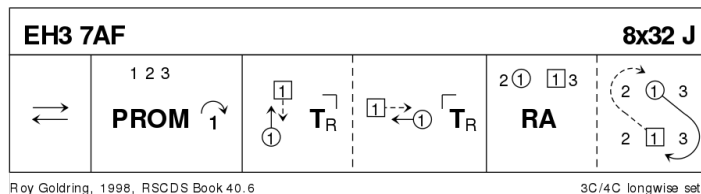

uaine / green - video at <https://youtu.be/9ljkDZGtPsk>

2 H.I.S.C.D. R32 · 3/4L

Lisbeth & Douglas Henderson: Scottish Dance Archives · Crib: E-cribs · Diagram: Keith Rose's Diagrams

The title means: »Happiness is SCD«

- 1- 1c turn RH ending BtoB in 2pos, 1W facing up and 1M down (2c up) | all set up/dn in DTr ; 1c turn 4cnr RH, and pass Rsh to face 1cnr
- 9- SetH&G , at end set advancing to P
- 17- 1c turn RH once ending BtoB, 1M facing up and 1W down | All Set up&dn in DTr ; 1c turn 2cnr RH and pass Rsh to 2pl (2,1,3)
- 25- All Circle6 and Back

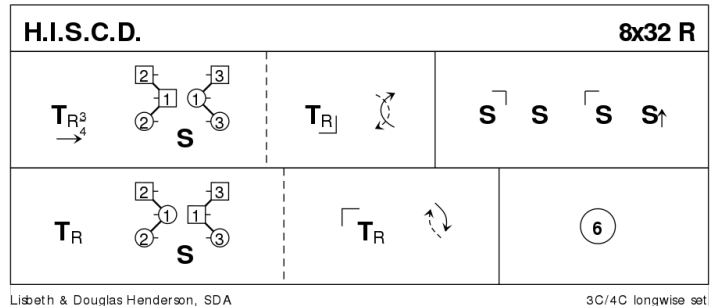

Lisbeth & Douglas Henderson, SDA

3C/4C longwise set

òmarach / amber - Video at https://youtu.be/_GcRLKU_JG0

3 12 COATES CRESCENT S32 · 4/4L

RSCDS: RSCDS XL 5 · Crib: E-cribs · Diagram: Keith Rose's Diagrams

- 1- All 4 couples set, cross RH ; repeat
- 9- 1c & 4c dance NHJ to meet in centre, with person opposite dance NHJ out sides, and cast to own places ; 1c lead down to 4pl (2c+3c+4c up on 15-16))
- 17- 3c+4c (middle couples) R&L
- 25- 2c+3c & 4c+1c RHA ; LHA

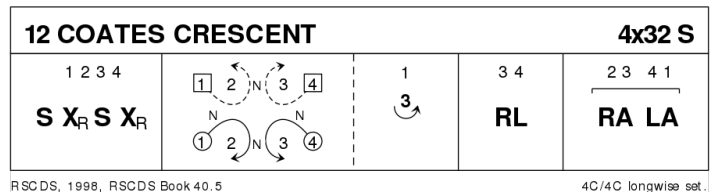

uaine / green - video at <https://youtu.be/9ljkDZGtPsk>

4 BEST SET IN THE HALL J32 · 3/4L

Helen Greenwood: RSCDS XLVI 7 · Crib: E-cribs · Diagram: Keith Rose's Diagrams

- 1- 1c set | 1W (1M follows) casts off 2, crosses, W dances up behind M line, and M dances up the middle, 1c face 1cnr (2c up)
- 9- 1c set to 1cnr | 1c cast Rsh round each other to 3cnr position **while{2}** 1cnrs dance into centre, and swivel R to face own cnr ; repeat, 1cnrs finishing in exchanged places, and 1c facing 2cnr
- 17- Repeat with 2cnrs (3x,1x,2x)
- 25- All chase clw ½ round ; all turn RH. (2,1,3)

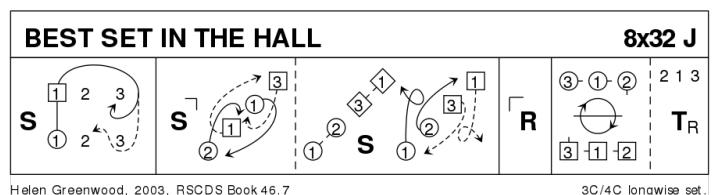

To: Auckland Region President, Campbell MacKay, nov. 2003

òmarach / amber - video at <https://youtu.be/CZGPC1guhW0>

5 ANNIVERSARY REEL R32 · 4/4L

Sheila Muir: RSCDS XXXVI 7 · Crib: E-cribs · Diagram: Keith Rose's Diagrams

- 1-- 1c cross RH, cast off (2c up), ½ Fig8 up (2,1,3,4)
 9-- 1W Reel3 across with 2c (Lsh to 2M) **while**{8} 1M ½ Lsh Reel3 with 3c then ½ Reel3 with 4c (Rsh to 4M)
 17-- 1c+3c LHA ; 1W+2c & 1M+4c RHA
 25-- 1c pass Lsh into ½ Reel4 across with 3c (3c to 2pl), at end 1c turn RH to 3plx RHJ **while**{2} 4c set advancing to join in | 1c+4c ½ RHA (2,3,4,1)

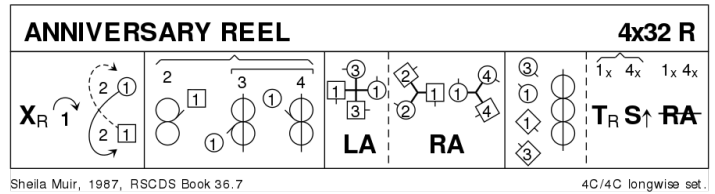

òmarach / amber - video at <https://youtu.be/iQO-aWU5ZY4>

6 "DEER" FRIENDS S32 · 3/4L

Bob Anderson: The Saint Martin Coll. of New Scottish Country Dances vol. 1 · Crib: E-cribs · Diagram: Keith Rose's Diagrams

- 1-- 1c cross down (2c up), cast behind 3c, cross RH and cast up | turn P LH and join RH with 3c into diagonal line
 9-- 1c+3cnrs set R (change hands with cnr) {1}, 1c+3cnrs turn LH ½, 1c joining RH in middle {1} | 3cnrs set along the diagonal **while**{2} 1c set R {1} and turn LH ½ to face 3c {1} ; ½ Reel4 on 1diag, finish on 2diag, 1c LHJ to P and RHJ to 4c
 17-- Repeat [9-16] with 4cnrs, 1c at the end crossing LH to (3x,1x,2x)
 25-- All S&Link3 twice (2,1,3)

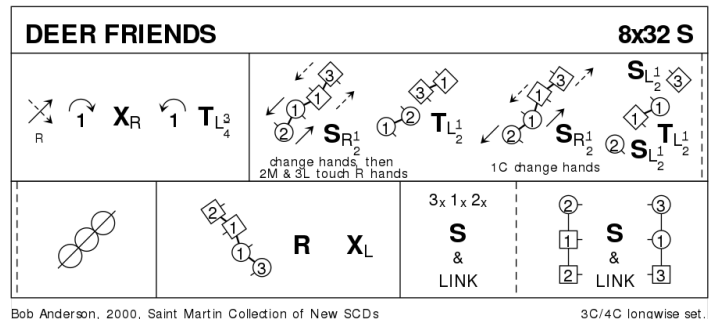

òmarach / amber - video at <https://youtu.be/zdUzqkvTAaA>

7 ST ANDREW'S FAIR J32 · 3/4L

Roy Goldring: Five Scottish Country Dances 1982 · Crib: E-cribs · Diagram: Keith Rose's Diagrams

- 1-- 1c cross RH | cast off 2 (2c up) ; cross LH and cast up (2,1,3)
 9-- All turn RH ½ | retain hold & set ; all chase clw to own sides (3,1,2)
 17-- 3c+1c+2c Circle6 and back
 25-- All turn LH ½ | retain hold & set ; all chase cclw to (2,1,3)

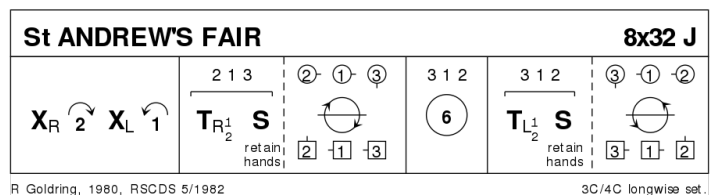

note: 3c does not move on bars 1-8.

uaine / green - video at <https://youtu.be/Q4-pC1HVLE0>

8 JEAN MARTIN OF ABERDEEN S32 · 3/3L

Muriel A Johnstone: Magazine Dances 2005-2009 · Crib: E-cribs · Diagram: Keith Rose's Diagrams

- 1- 1c Turn RH, cast (2c up) ; All circle6 L $\frac{3}{4}$ into lines across (W facing down, M up)
- 9- All set | change places RH with P ; All circle6 L left $\frac{3}{4}$ and end in middle facing up (3,1,2) for
- 17- Allemande (2,1,3)
- 25- 1c+3c Bourrel : 1M+3W set adv. | Turn BH $\frac{3}{4}$ & twirl to end BtoB in middle, 3W facing up & 1M down **while**{4} 1W+3M chase cclw to face P set to P | Turn BH $\frac{3}{4}$ to (2,3,1)

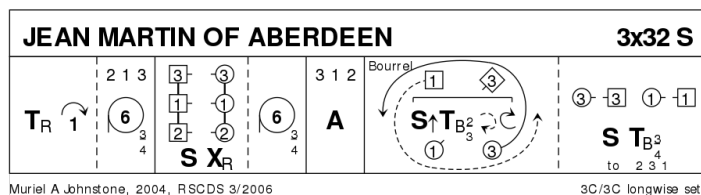

òmarach / amber - <https://youtu.be/WA37PEnBzZY>

9 FATHER CONNELLY'S JIG J64 · 4/4L

John Drewry: The Donside Book · Crib: E-cribs · Diagram: Keith Rose's Diagrams

- 1- 1c+2c Set&Rotate (All set | petronella clw one place ; change places RH with P | chase one place clw) (2,1,3,4)
- 9- $\frac{1}{2}$ diagonal R&L with 1cnrs (W up, M down) **while**{4} the 2cnrs (2M+3W) set & cross RH, all cnrs face out ; $\frac{1}{2}$ Reels3 on the sides, 1c Rsh to 2cnr pos. (no loops at the end) (2x,1x,3x,4)
- 17- Repeat figure from these positions with 2cnr persons (in 3cnr positions ; M up, W down) (to 2,1,3,4), 2c+3c finishing with loops into
- 25- Reels3 across (Lsh to 1cnr) (2,1,3,4)
- 33- 1c cross down RH between 3c | cast Rsh round new 1cnr (4W resp. 3M) ; change places up/dn LH | cast L (3c up) to (2,3,1,4)
- 41-56 3c+1c+4c repeat the figures [9-24] above (2,3,1,4)
- 57- 3c+1c+4c Circle6 and back (optional: 2c join in for Circle8 and back) (1c step down, to 2,3,4,1)

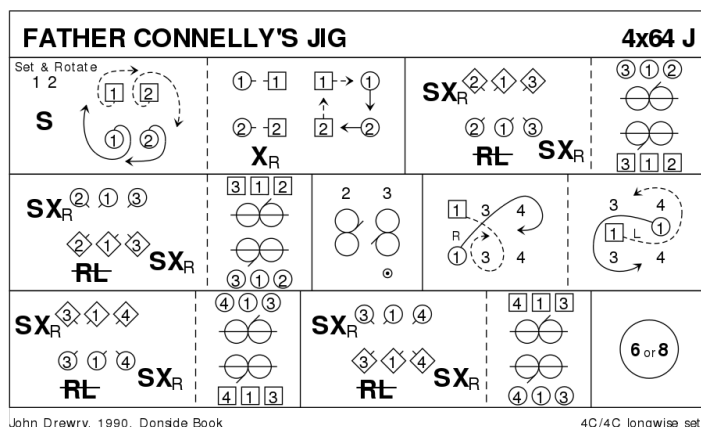

(note by Drewry: This is really two successive 3c dances of 32 bars, the figures of bars 9-24 being similar.)

dearg / red - video at <https://youtu.be/Cgng-Y3kZnl>

10 JOHN OF BON ACCORD R32 · 3/4L

Roy Goldring: RSCDS XXXIII 5 · Crib: E-cribs · Diagram: Keith Rose's Diagrams

- 1-16 4 progressive ½ Reels 3 across, as follows: 1c+2W (1c start Rsh to P) ; 1c+2M (start Lsh) ; 1c+3W (Rsh) ; 1c+3M (Lsh), 1c finish in 3pl a bit in from the sidelines (2c & 3c finish their reels in 1plx and 2plx)

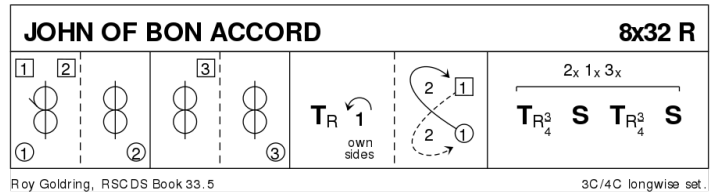

- 17- 1c turn RH, cast up one place on own sides (3c down) ; 1c ½ Fig8 round 2c (2x,1x,3x)
 25- All turn P ¾ RH to face P along the midline | All Set retaining RHJ ; all turn P ¾ RH | All Set (2,1,3)

òmarach / amber - video at <https://youtu.be/O7hRuGzTrL4>

INTERVAL

11 PELORUS JACK J32 · 3/4L

Barry Skelton: RSCDS XLI 1 · Crib: E-cribs · Diagram: Keith Rose's Diagrams

- 1- 1c cross RH, cast (2c up) ; 1c+3c RHA, finish 1M facing 1cnr, 1W behind him
 9- 1c in tandem +1cnrs ½ diagonal Reel3, Rsh to 3W (1M & 1W loop R singly for lead change, so 1W now leads P) ; ½ diagonal Reel3, Rsh to 2W (+ lead change)
 17- Continue pattern twice
 25- 2c+1c LHA ; 1c turn LH ½ | all set (2,1,3)

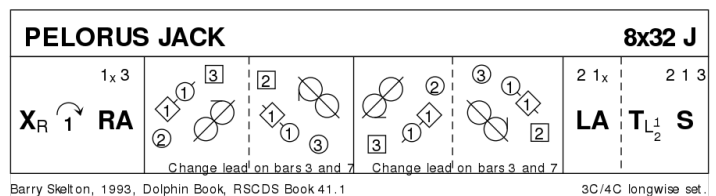

òmarach / amber - video at <https://youtu.be/qlg2H6gew7Y?t=177>

12 LADY SOPHIA LINDSAY R32 · 4/4L

Jean Attwood: Alexander Leaflets · Crib: E-cribs · Diagram: Keith Rose's Diagrams

On 2nd chord 3c+4c cross to (1,2,3x,4x)

- 1- 2c+3c RHA ; 2W & 3W with P following cast L round 1W & 4W »=2cnrs«
 9- 1M+2c & 3c+4M RHA ; 1W+2c & 3c+4W LHA
 17- 2c (on M side) & 3c (on W side) (still in tandem, W leading) opposing Reels 3 on sidelines, Lsh to 4W/1W "=4cnr", to 2,1,4x,3x, middle Cs facing each other up/dn
 25- 1c+4c set | cross RH on side ; set to P | cross RH (2,4,1x,3x)

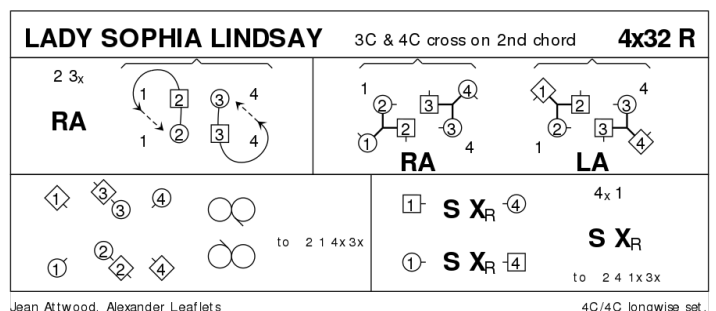

òmarach / amber - <https://youtu.be/KHqN7yIltyA>

13 A 100 YEARS BEHIND US! M32 · 3/3L

Jennie Hartley · Crib: E-cribs

- 1-- 1c long cast to 2pl (2c up), dance between 3c and cast up to face 1cnr
- 9-- 1c+1cnrs: centres set to cnr | centres cast away to cnr behind as cnrs dance in and face back ; repeat and 1c turn R about to face 2cnr
- 17-- 1c+2cnrs repeat (3x,1x,2x)
- 25-- 3W with 1W+2W following cast down **while{4}** 2M with 1M+3M following cast up (2x,1x,3x) ; 2c cross RH as 1c+3c ½RHA | All set (2,3,1)

repeat 2 times more in Strathspey time, 3 times in Reel time.

dearg / red - video at <https://youtu.be/7PQsOWeafE0>

Watford's centenary medley

Dance devised by Jennie Hartley with input from members to commemorate the Centenary of Watford and West Herts Scottish Society

14 FLORA'S FANCY J32 · 3/4L

Members of Tucson Branch and Seven Pipers Scottish Society C.D. class: RSCDS XLIX 8 · Crib: E-cribs · Diagram: Keith Rose's Diagrams

- 1-- 1c set | cast off (2c up) ; Teapots R
- 9-- tandem Reel3 across with 2c: 1W (with 1M close behind) Rsh to 2W (2,1,3)
- 17-- 1c set | ¾ turn RH ; Teapots L
- 25-- tandem Reel3 across with 3c: 1M (with 1W close behind) Rsh to 3M (2,1,3)

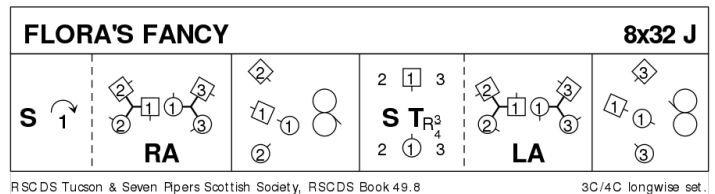

uaine / green - video at <https://youtu.be/BJIWjc83F8A>

15 MISS JOHNSTONE OF ARDROSSAN R32 · 5/5L

Roy Goldring: 14 Social Dances for 2000 · Crib: E-cribs · Diagram: Keith Rose's Diagrams

- 1-- 1c set | cast off (2c up) ; 1c followed by 3c dance up and cast round 2c to (2,3,1,4,5)
- 9-- 1c+4c+5c mirror Reels3, 1c cross down to enter, 4c start out and up (2,3,1x,4,5)
- 17-- 2c+3c+1c mirror Reels3, 1c cross up to enter, 3c start out and down
- 25-- 1c set | cast off to 4pl (4c up) ; 1c followed by 5c dance up and cast round 4c to (2,3,4,5,1)

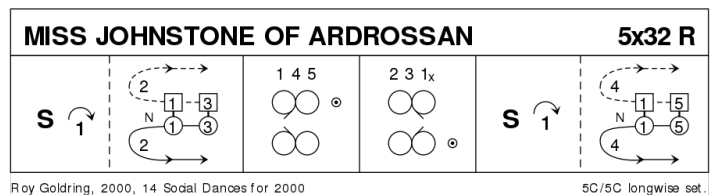

òmarach / amber - video at https://youtu.be/S_6xmqAc9RE

16 SALUTE TO IAN ROBERTSON

S32 · 3/3L

Jane and Brian Rose · Crib: E-cribs · Diagram: Keith Rose's Diagrams

- 1-- 2c cross down RH and cast up to 2plx ;
cross up RH and cast off to face 1cnrs
- 9-- 2c set to and turn corners, to (1,2x,3)
- 17-- Reels3 on own sides, giving hands, to
start 2c cross down (1,2,3)
- 25-- Slipknot: 6 bars of a 3C knot, (to
3x,2x,1x) | 3c+2c ½ LHA as 1c turn LH
½ (2,3,1)

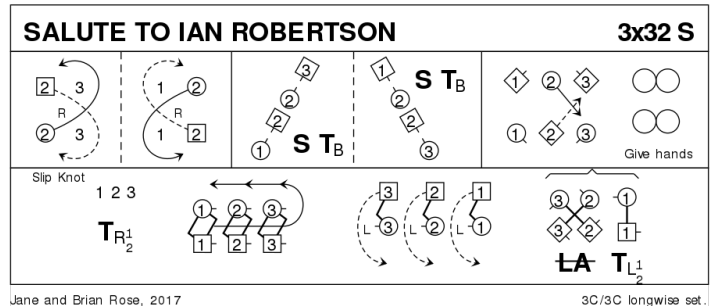

òmarach / amber - video at <https://youtu.be/XolzmcOvPys>

17 THE AUSTRALIAN LADIES

R32 · 3/4L

Robert M Campbell: Glasgow Assembly And Other Scottish Dances · Crib: E-cribs · Diagram: Keith Rose's Diagrams

- 1- 1c cross RH | cast off two (2c+3c up) ;
3c+1c RHA
- 9- 1c lead to top, cross and cast to 2pl (3c
down) ; 2c+1c LHA (2,1,3)
- 17-32 2c+3c («corners») set and change
place RH four times following the track
of R&L (3M&2W make polite turns)
while{16} 1c cross (across or up/dn)
RH and cast R round the corner four
times.

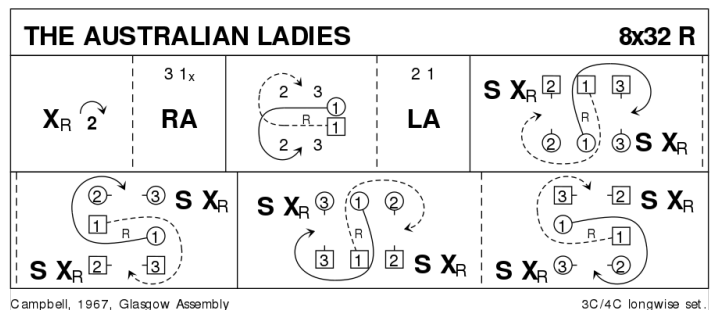

Note by the deviser in TacTalk of jan. 1986: on [17-32] the corners set »as written«; they do not split the setting as is customary in »J.B. Milne«.

Devised in May 1967 in New Zealand by Bob Campbell of Canada for Jean Conway, Elma See, Lorraine Dyall, and Margaret Gray of the Newcastle (Australia) Colleges Strathspey and Reel Club.

òmarach / amber - video at <https://youtu.be/vfbk64eyaEA>

18 THE ROBERTSON RANT S80 · 4S

Mrs Douglas Winchester: RSCDS XXXIX 8 · Crib: E-cribs · Diagram: Keith Rose's Diagrams

- 1– All Circle8 and back
 9– Double L chain (women ½ RHA, turn opposite M LH ; ½ RHA, turn P LH, to own places)
 17– 1c+3c Reel4, (W pass left shoulder, M set on [17-18], at the end W slow down and M speed up, face and acknowledge P and pull back inner shoulder to face corners.
 25– All set to corner H.Schottische ; turn cnr BH twice
 33-48 2c+4c repeat [17-32]
 49– Women Circle4 L (at end pull back Rsh to face out) ; set to and turn P BH.
 57– Men circle4 R, pull back Lsh ; set to and turn P BH.
 65– G-Chain (one step per hand)
 73– Promenade cclw round the set in Allemande hold, M bring W into middle of set and hold RH for bow and curtsy

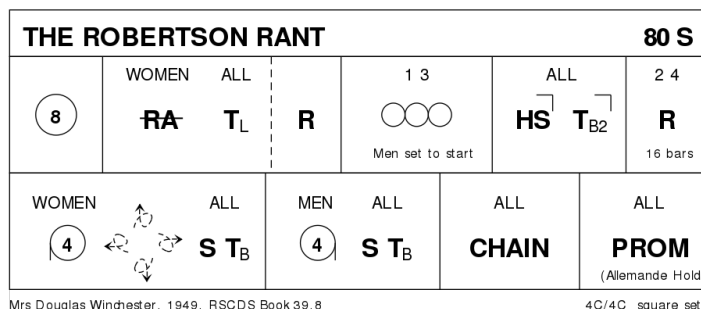

òmarach / amber - video at <https://youtu.be/bwv-XApNsr4>

19 THE FINDLAYS' JIG J32 · 3/4L

Roy Goldring: 14 Social Dances for 2000 · Crib: E-cribs · Diagram: Keith Rose's Diagrams

- 1– 1c lead down the middle and up, 2c+3c step in for
 9– 1c+2c+3c Allemande (to 3,2,1)
 17– 1c long cast to 1pl (3c+2c down) ; 2c repeat (1c+3c down) (2,1,3)
 25– Circle6 and back

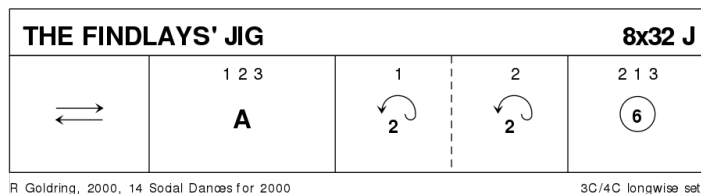

uaine / green - video at <https://youtu.be/90PAP7p12fQ>

20 MAIRI'S WEDDING R40 · 3/4L

James B Cosh: Twenty Two SCD · Crib: E-cribs · Diagram: Keith Rose's Diagrams

- 1– 1c turn RH | cast (2c up) ; turn LH to face 1cnrs
 9– 1c ½Reel4 with 1cnrs (pass P Lsh) ; Repeat with 2cnrs
 17– Repeat with 3cnrs (1cnr person) ; Repeat with 4cnrs (2cnr person)
 25– 1W+2c & 1M+3c Reels3 across, Lsh to 1cnr
 33– 2c+1c+3c circle6 and back

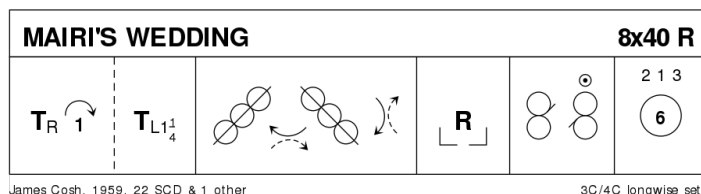

Note: Cosh explicitly tells 1c to pass Lsh in [9-24]; however the Rsh pass is quite common, and nicknamed »Mairi's Divorce«.

òmarach / amber - video at <https://youtu.be/r7qyFX-EbCg>